



Installation Instruction For DMEGC PV Modules

Installation Instruction For DMEGC Photovoltaic Modules



Table of Contents:

1. Purpose of this guide -----	3
1.1 General	
2. Safety precaution -----	5
3. Mechanical Installation -----	6
3.1 Selecting the location	
3.2 Selecting the proper support frame	
4. General installation -----	7
4.1 Mounting with Bolts	
4.2 Mounting with Clamps	
4.3 Installation location schematic	
5. Electrical Installation Ground-----	12
5.1 Installation	
6. Maintenance and Care-----	14
7. Maintenance Disclaim of liability-----	15
Accessories: Mechanical installation and electrical performance ratings-----	16



1. Purpose of this guide

This guide contains information regarding the installation and safe handling of DMEGC photovoltaic module (hereafter is referred to as “module”).

All instructions should be read and understood before attempting to install. If there are any questions, please contact our sales department for further explanation. The installer should conform to all the safety precautions in the guide when installing the module. Local codes should also be followed in such installation.

Before installing a solar photovoltaic system, the installer should become familiar with the mechanical and electrical requirement for such a system. Keep this guide in a safe place for further reference (care and maintenance) and in case of sale or disposal of the module.

1.1 General

- Installing solar photovoltaic systems may require specialized knowledge and appropriate technical skills. Therefore installation should be performed only by qualified person.
- All modules come with a permanently attached junction box.
- The installer should assume the risk of all injury that might occur during installation, including, without limitation, the risk of electric shock.
- One individual module may generate DC voltages greater than 30 volts when exposed to direct sunlight. Contact with a DC voltage of 30V or more is potentially hazardous.
- When disconnecting wires connected to a photovoltaic module that is exposed to sunlight, an electric arc may result. Such arcs may cause burns, may start fires and may otherwise create problems. Therefore be extremely careful!
- Photovoltaic solar modules change light energy to direct-current electrical energy. They are designed for outdoor use. Modules may be ground mounted, mounted on rooftops, vehicles or boats. Proper design of support structures are responsibility of the system designer and installer. Use of mounting holes is suggested in a following paragraph.
- Do not attempt to disassemble the module, and do not remove any attached nameplates or components.



- Do not apply paint or adhesive to module top surface.
- Do NOT artificially focus the light on the module.



- When installing the system, abide with all local, regional and national statutory regulations. Obtain a building permit where necessary. Abide with any local and national regulations when mounting on vehicles or boats.

2. Safety precautions

Solar modules produce electrical energy when light shines on their front surface. The DC voltage may exceed 30 V. If modules are connected in series, the total voltage is equal to the sum of the individual module voltages. If modules are connected in parallel, the total current is equal to the sum of individual module currents.

- Keep children well away from the system while transporting and installing mechanical and electrical components.
- Completely cover the module with an opaque material during installation to keep electricity from being generated.
- Do not wear metallic rings, watchbands, ear, nose, lip rings or other metallic devices while installing or troubleshooting photovoltaic systems.



- Use only insulated tools that are approved for working on electrical installations.
- Abide with the safety regulations for all other components used in the system, including wiring and cables, connectors, charging regulations, inverters, storage batteries and rechargeable batteries, etc.
- Use only equipment, connectors, wiring and support frames suitable for use in a solar electric system. Always use the same type of module within a particular photovoltaic system.
- Rated electrical characteristics tolerance: $P_{max} \pm 3\%$; $V_{oc} \pm 3\%$; $I_{sc} \pm 4\%$; Power sorting tolerance [0; +5W] under standard test conditions (irradiance of 1000mW/cm², AM 1.5 spectrums and a cell temperature of 25°C (77°F)).

Under normal conditions, the module will produce current and voltages that are different from those listed in the data sheet. Data sheet values are expected at standard test conditions.



3. Mechanical Installation

3.1 Selecting the location

- Select a suitable location for the module installation, where they receive maximum sunlight throughout the year.
- The module must be facing true south in northern latitudes and true north in southern latitudes.
- For detailed information on the best elevation tilt angle for the installation, refer to standard solar photovoltaic installation guides or a reputable solar installer or systems integrator.
- The module should not be shaded at any time of the day.
- Do not use module near equipment or in locations where combustible materials generated or collected.
- DMEGC recommends that the module should be installed at a working ambient temperature of $-20\text{ }^{\circ}\text{C}$ ~ $50\text{ }^{\circ}\text{C}$. The module's limit working ambient temperature range is from $-40\text{ }^{\circ}\text{C}$ to $85\text{ }^{\circ}\text{C}$.

3.2 Selecting the proper support frame

- Always observe the instructions and safety precautions included with the support frame to be used with the module.
- No attempt must be made to drill holes in the glass surface of the module. Doing so will void the warranty.
- Do not drill additional mounting holes in the frame of the module. Doing so will void the warranty.
- The support module mounting structure must be made of durable, corrosion-resistant and UV-resistant material.

4. General installation

- Do not lift the module by grasping the module's junction box or electrical leads.
- Do not stand or step on the module.
- Do not drop modules or allow objects to fall on modules.
- To avoid the breakage of the glass of the module, do not place any heavy objects on the module.
- Do not set the module down hard on any surface.
- Inappropriate transport and installation may break the glass of the module.
- It is suggested Modules are installed at least 10cm higher from the ground.

4.1 Mounting with Bolts

- Modules can be attached through the mounting holes on the back frame of the module, by fixing the module to the support rails with bolts.
- The frame of each module has 8 mounting holes, ideally placed to optimize the load handling capability, to secure the modules to supporting structure.
- To maximize mounting longevity, DMEGC strongly recommends the use of corrosion proof (stainless steel) attachment hardware.
- The mounting details are shown in the following figures.

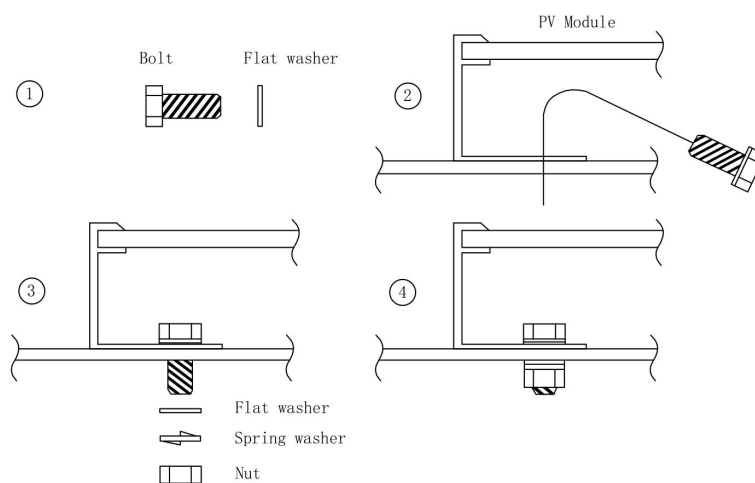

- The tightening torque (suggest stainless steel M8 bolts) should be around 15-20 Nm.

4.2 Mounting with Clamps

- Use at minimum 4 clamps to attach modules to the mounting rails.
- Modules clamps should not come into contact with the front glass and must not deform the frame.
- Be sure to avoid shadowing effects from the module clamps.
- When choosing this type of clamp-mounting method, use at least four clamps on each module, two clamps should be attached on each long sides of the module (for portrait orientation) or each short sides of the module (for landscape orientation). Depending on local wind and snow loads, additional clamps may be required to ensure that modules can bear the load.
- The mounting details are shown in the following figures.

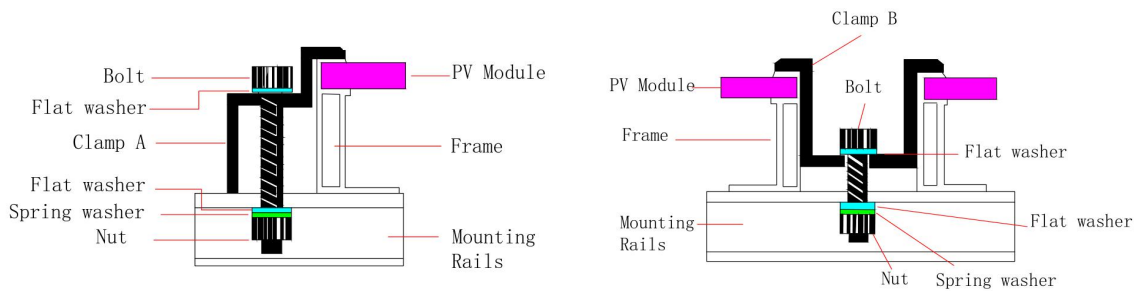

4.3 Installation location schematic.

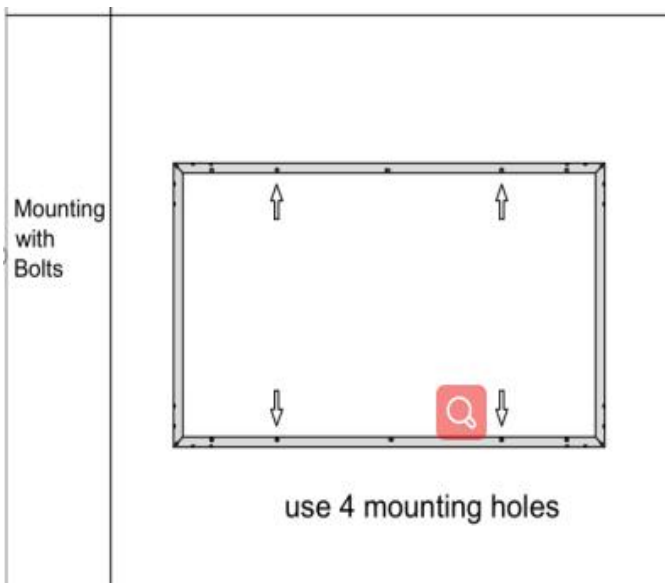

Module type	Pressure +2400Pa/-
	2400Pa
	Dimensions(mm) (L*W)
Group 1	1723x1134/1722x1134/1708x1134
Group 2	2279x1134/2278x1134
Group 3	1755x1038/1780x1052
Group 4	2115x1052/2094x1038/2104x1040

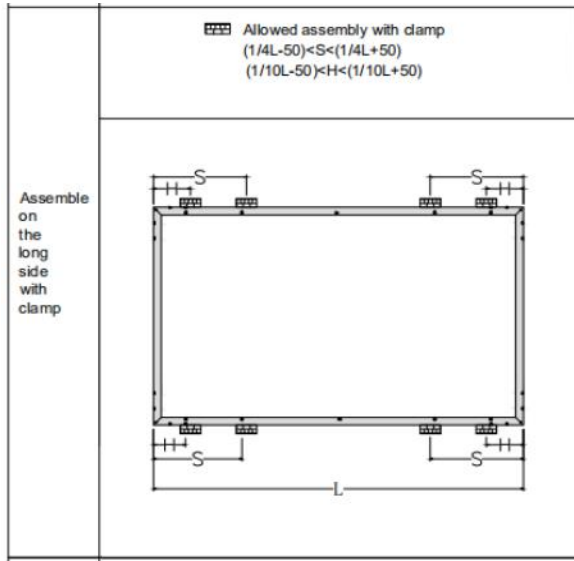

Module type	Pressure
	+5400Pa/-2400Pa
	Dimensions(mm) (L*W)
Group 1	1723x1134/1722x1134/1708x1134
Group 2	2279x1134/2278x1134
Group 3	1755x1038/1780x1052
Group 4	2115x1052/2094x1038/2104x1040

Note: 'L' series glass with a thickness of 2.5mm can withstand pressure of +5400Pa/ -2400pa; The thickness of 2.0mm can only withstand pressure of +2400Pa/ -2400pa.

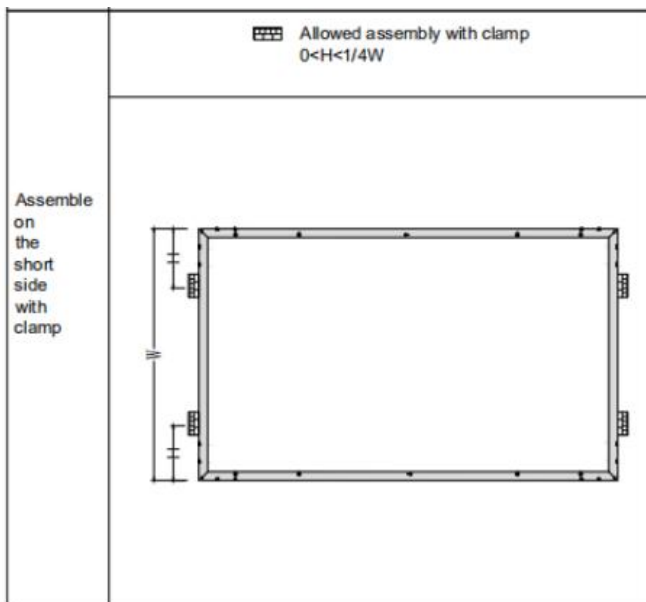

Module type	Pressure
	+2400Pa/-2400Pa
	Dimensions(mm) (L*W)
Group 1	1723x1134/1722x1134/1708x1134
Group 2	2279x1134/2278x1134
Group 3	1755x1038/1780x1052
Group 4	2115x1052/2094x1038/2104x1040

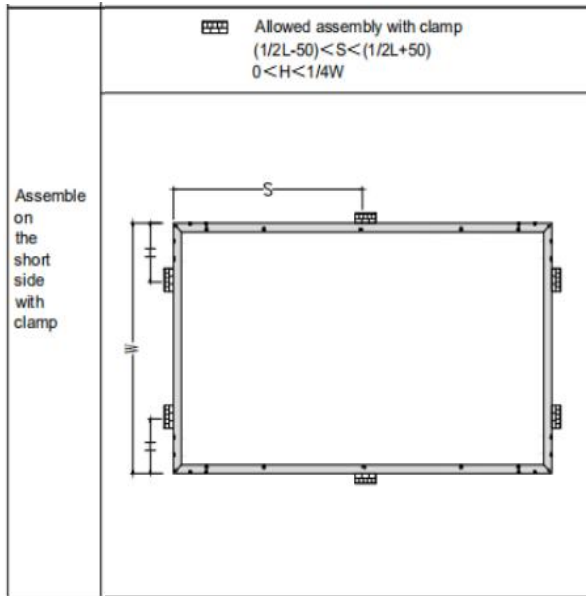

Module type	Pressure
	+5400Pa/-2400Pa
	Dimensions(mm) (L*W)
Group 1	1723x1134/1722x1134/1708x1134
Group 2	2279x1134/2278x1134
Group 3	1755x1038/1780x1052
Group 4	2115x1052/2094x1038/2104x1040

Note: The glass of L series modules is 2.5mm thick and 8 mounting holes can withstand the pressure of +5400Pa/ -2400pa;The thickness of 2.0mm can only withstand pressure of +2400Pa/ -2400pa.

5. Electrical Installation grounding

- Proper grounding is achieved by bonding the module frame(s) and all metallic structural members together continuously using a suitable grounding conductor. The grounding conductor or strap may be copper, copper alloy, or any other material acceptable for use as an electrical conductor per respective National Electrical Codes. The grounding conductor must then make a connection to earth using a suitable earth ground electrode.
- Under normal conditions, a module is likely to experience conditions that produce higher current and/or voltage than reported at standard test conditions. Accordingly, the values of I_{sc} and V_{oc} marked on this PV module should be multiplied by a factor of 1,25 when determining component voltage ratings, conductor current ratings, and size of controls (e.g. inverter) connected to the PV output.
- Potential equalization of the solar generator is prepared in the factory and is recommended. It can be carried out using the existing grounding bores on the long sides of the frame or suitable clamps with integrated grounding pins in accordance with the valid local regulations.
- It is advisable to install lightning protection in exposed locations. The solar modules should be incorporated in existing lightning protection equipment.
For this, take into account the relevant valid regulations (e.g. EN 62305 and VDE 100).
- The devices have to be installed in accordance with the grounding device manufacturer's specified instructions.

5.1 Installation

- Do not use modules of different configurations in the same system.
- Several modules are connected in series and then in parallel to form a PV array, especially for application with a high operation voltage. If modules are connected in series, the total voltage is equal to the sum of individual voltages.

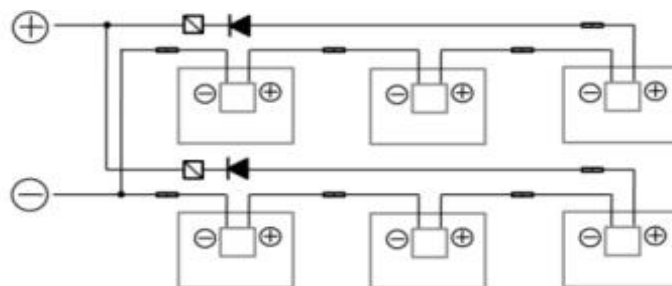

 二极管
diode
  过电流保护器
overcurrent protector
  连接器
connector

先串联后并联连接
Connecting in parallel
after Connecting in series

- For applications requiring high currents, several modules can be connected in parallel; the total current is equal to the sum of individual currents.

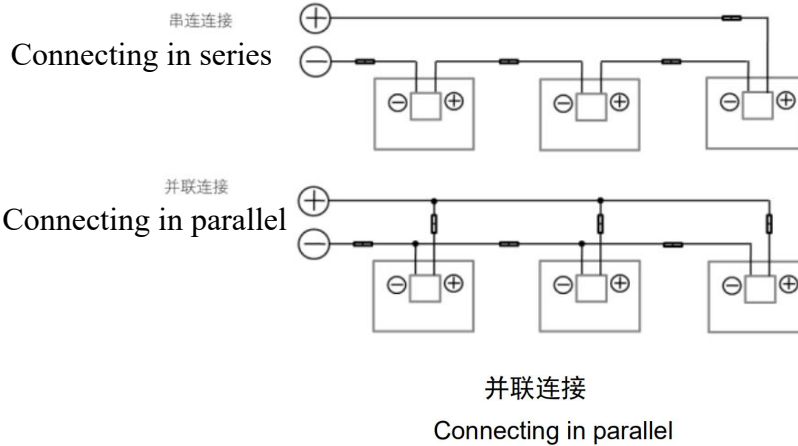

- The number of modules in series and in parallel shall be designed reasonably according to the system configuration.
- The module is supplied with Multi-Contact (MC) or MC compatible connectors to use them for the electrical connections of the system. Use the National Electric Code to determine system wiring size, type and temperature rating of conductors to be connected to the module's connectors. Wiring connected to the modules should be #12 AWG, LAPP 4mm² (minimum) and must be temperature rated at 90°C (minimum).
- The cross section area of cable and the capacity of connector must be selected to suit the maximum system short circuit current, otherwise the cable and connector will be overheated under large current.



6. Maintenance and care

DMEGC recommends the following maintenance in order to ensure optimum performance of the module:

- Clean the glass surface of the module as necessary. Always use water and a soft sponge or cloth for cleaning.
- A mild, nonabrasive cleaning agent can be used to remove stubborn dirt.
- Check the electrical and mechanical connections every six months to verify that they are clean, secure and undamaged.
- If any problems arise, users should have them investigated by a competent specialist.
- Attention, observe the maintenance instructions for all components used in the system, such as support frames, charging regulators, inverters, batteries etc.



7. Disclaimer of liability

Because the use of this manual and the conditions or methods of installation, operation, use and maintenance of photovoltaic (PV) product are beyond DMEGC's control, DMEGC does not accept responsibility and expressly disclaims liability for loss, damage, or expense arising out of or in any way connected with such installation, operation, use or maintenance.

No responsibility is assumed by DMEGC for any infringement of patents or other rights of third parties, which may result from use of the PV product. No license is granted by implication or otherwise under any patent or patent rights.

The information in this manual is based on DMEGC's knowledge and experience and is believed to be reliable; but such information including product specification (without limitations) and suggestions do not constitute a warranty, expresses or implied. DMEGC reserves the right to change the manual, the PV produce, the specifications, or product information sheets without prior notice.



Accessories: Mechanical installation and electrical performance ratings

Mechanical load design pressure:

According to the different installation environment, the installation environment can be divided into two conditions, and the appropriate installation mode can be selected according to the local actual situation.

Low/normal load conditions, applicable to most environmental conditions: maximum static load on the back of the modules is 2400pa(equivalent to wind pressure), maximum static pressure on the front is 2400pa(equivalent to wind pressure and snow pressure).

High load conditions, suitable for harsh environmental conditions (such as storm and snow, etc.): the maximum static load on the back of the assembly is 2400pa(equivalent to wind pressure), and the maximum static pressure on the front is 5400pa(equivalent to wind pressure and snow pressure), which is also the highest pressure requirement in IEC standards.

Method of labeling the load capacity of the modules: Measured by design load and safety factor γ_m , where $\gamma_m \geq 1.5$.

For dynamic load, such as rafale, the safety factor needs to be increased by 3 times, that is, the maximum wind pressure capacity of rafale is 800Pa, that is, the wind speed is less than 130 km/h, which is equivalent to the wind speed of a grade 12 typhoon.

Module nameplate parameters required:

Overcurrent protection value :15A/20A;The $I_{sc} \pm 4\%$; $V_{oc} \pm 3\%$.

Nominal Module Operator Temperature (NMOT)	45°C±2°C		
	PERC MONO	POLY	MONO
Temperature Coefficient of I_{sc}	+0.060%/°C	+0.057%/°C	+0.043%/°C
Temperature Coefficient of V_{oc}	-0.300%/°C	-0.308%/°C	-0.320%/°C
Temperature Coefficient of P_{max}	-0.0390%/°C	-0.406%/°C	-0.420%/°C



Installation Instruction For DMEGC PV Modules

Module type:

1.	DM400M10-54HBW	GROUP1
2.	DM405M10-54HBW	GROUP1
3.	DM410M10-54HBW	GROUP1
4.	DM390M10-54HBB	GROUP1
5.	DM395M10-54HBB	GROUP1
6.	DM400M10-54HBB	GROUP1
7.	DM540M10-72HSW	GROUP2
8.	DM545M10-72HSW	GROUP2
9.	DM550M10-72HSW	GROUP2
10.	DM375M6-60HBW	GROUP3
11.	DM380M6-60HBW	GROUP3
12.	DM385M6-60HBW	GROUP3
13.	DM365M6-60HBB	GROUP3
14.	DM370M6-60HBB	GROUP3
15.	DM375M6-60HBB	GROUP3
16.	DM380M6-60HBB	GROUP3
17.	DM450M6-72HSW	GROUP4
18.	DM455M6-72HSW	GROUP4
19.	DM460M6-72HSW	GROUP4

This manual is for DMEGC photovoltaic module products listed above.